

# Precision Angle Displacement Sensor

Capacitive, without contact rings

Series 88600

Code:	88600 EN
Delivery:	ex stock / 5 weeks
Warranty:	24 months

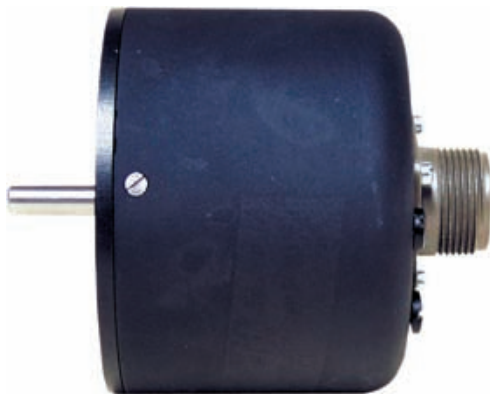

- Measurement ranges up to 160°
- High linearity up to 0.05% F.S.
- Contact-free transmission
- Integrated amplifier
- Robust, maintenance-free
- Very low inertia moment
- Special versions by request

## Application

The 88600 series combines the precision of expensive optical angle encoders with high resolution and an analog output, without being subject to the restricted applications of potentiometric angle sensors.

Typical applications

- ▶ Position feedback in servo-systems
- ▶ Zero detectors
- ▶ Pendulum weighing machines
- ▶ Cam and butterfly flap positions
- ▶ Twist angles
- ▶ Angular actuators
- ▶ Optical angle measurements
- ▶ Jockey roller controllers

## Description

This capacitive DC/DC angle displacement sensor with integrated amplifier only requires a DC voltage for a power supply and delivers an output voltage that is proportional to the angular position of the shaft. The shaft can be turned clockwise or counterclockwise with a permissible angular speed of up to 18,000 °/s (option).

A highly accurate differential rotary capacitor is used to convert the angle into an electrical voltage. The integrated electronics consists of an oscillator, demodulator and amplifier. It can display the measurement signal directly or can, for instance, pass it to process monitoring equipment.

Power supply and transmission of measured signals is without contact within the sensor. Operation is therefore maintenance-free. The precision roller bearings used give the sensor a long service life.

Parts that are important for the function are made from material with no internal stresses and protected against corrosion.

## Mounting instructions

The three threaded holes on the front plate (shaft side) allow the sensor to be mounted in any position. To determine the angular position of the measuring range, the shaft has a reference groove and the front face a reference hole (see rear).

**Technical Data**

Model	Operating Measurement Range 1.	Non-Linearity (% F.S.)	Possible Measurement Range 1.	Non-Linearity in Possible Measurement Range	Position of Measurement Range 1. + 2.	Output Voltage mV/ °
88600-000	± 30 °	≤ ± 0.05 %	± 40 °	≤ ± 0.10 %	0° ± 3°	100
88601-000	+ 10 ° ... + 70 °	≤ ± 0.05 %	0 ... + 80 °	≤ ± 0.10 %	+ 40° ± 3°	100
88602-000	- 10 ° ... - 70 °	≤ ± 0.05 %	0 ... - 80 °	≤ ± 0.10 %	- 40° ± 3°	100
88603-000	± 60 °	≤ ± 0.10 %	± 80 °	≤ ± 0.15 %	0° ± 3°	100
88603-001	± 60 °	≤ ± 0.05 %	± 80 °	≤ ± 0.10 %	0° ± 3°	100
88603-002	+ 20 ° ... + 140 °	≤ ± 0.10 %	0 ... + 160 °	≤ ± 0.15 %	+ 80° ± 3°	50
88603-003	+ 20 ° ... + 140 °	≤ ± 0.05 %	0 ... + 160 °	≤ ± 0.10 %	+ 80° ± 3°	50
88603-004	- 20 ° ... - 140 °	≤ ± 0.10 %	0 ... - 160 °	≤ ± 0.15 %	- 80° ± 3°	50
88603-005	- 20 ° ... - 140 °	≤ ± 0.05 %	0 ... - 160 °	≤ ± 0.15 %	- 80° ± 3°	50

**Electrical values**

Excitation voltage: 15.00 V DC (other voltages, refer to options), with protection against polarity reversal

Excitation current: ≤ 30 mA

Output: short-circuit proof, best linearity at 1 kΩ load

ripple ≤ 20 mV<sub>pp</sub> /400 kHz

impedance < 2 Ω

Repeatability: ≤ 0.01 %

Resolution: < 0.01 °

Electrical zero adjustment: ± 3 %

Internal carrier frequency: 400 kHz

**Environmental conditions**

Range of operation temperature: 0 °C ... + 75 °C

Range of storage temperature: - 55 °C ... + 125 °C

Thermal sensitivity shift: ≤ ± 0.027 % F.S./K

**Mechanical values**

Area of rotating: continuous rotation is possible, no mech. stoppers

Torque: breakaway torque 49 x 10<sup>-3</sup> Ncm  
slip torque 34 x 10<sup>-3</sup> Ncm

Moment of inertia: 0.76 gcm<sup>2</sup>

Max. shaft load: radial: 44 N  
axial: 31 N

Durability of the ball bearing: ≈17 000 h at 10 RPM and 44 N axle load

Mounting position: irrespective of its position

Maximum angular speed: 1440 °/s, with ≤ 2 % output voltage drop  
optionally: 18.000 °/s

Weight: approx. 400 g

**Dimensional drawing**

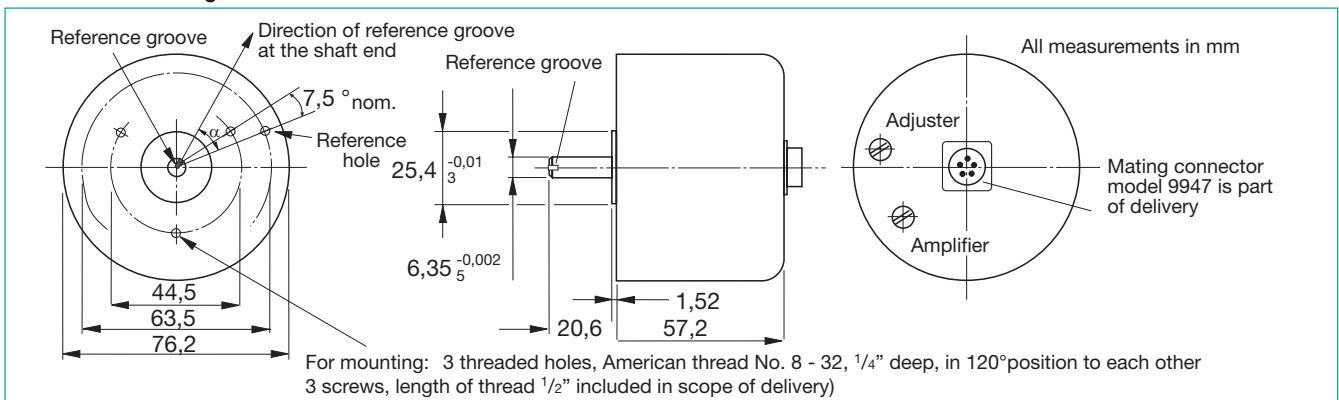

**Wiring diagram for remote zero**

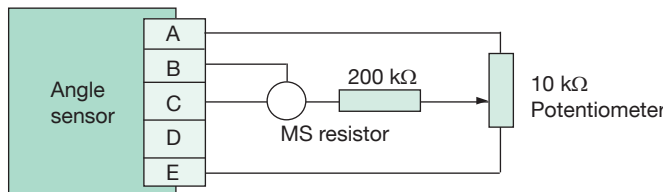

**Wiring code**

- A: + Excitation
- B: Excitation ground
- C: Remote Zero
- D: + Signal output
- E: Signal ground

**Block diagram**

