

Precision Torque Sensor

For non-rotating applications

Model 8625

Code:	8625 EN
Delivery:	ex stock / 4 weeks
Warranty:	24 months

CAD data 2D/3D for this sensor:
Download directly at www.traceparts.com
Info: refer to data sheet 80-CAD-EN



- Measurement ranges from 0 ... 0.005 Nm to 0 ... 5000 Nm
- High accuracy measurement ≤ 0.1 % F.S.
- Standardized output signal
- Extremely compact design
- Manufacturer calibration for right- and/or left-handed torque (optional)

Application

This torque sensor is designed for both static and dynamic measurements on non-rotating applications. It is particularly suitable for torque measurements on, for instance, extremely small electrical actuating drives and micro mechanical actuator elements, but also for large reaction torques such as those occurring with extruders.

The high accuracy of measurement also makes this sensor ideal for use as a reference in many fields of industrial manufacture, or in laboratory research and development projects. Not containing any rotating parts, it requires no maintenance if properly used.

Other possible applications:

- ▶ Test setup for precision mechanics
- ▶ Measuring the frictional torque of bearings
- ▶ Measuring the torques applied to vehicle control elements
- ▶ Acquisition of breakage moments on screw caps

Description

The length, weight and volume of the unit have been optimized in such a way that axial forces and bending moments in the measuring range have a minimal effect on the sensor element. Shear strains in the torsion shaft are measured accurately by means of metal foil strain gauges connected as a Wheatstone Bridge on the sensor element. Applying a supply voltage generates an electrical output signal that is directly proportional to the applied mechanical torque.

The standardization of the sensor output signals means that it is easy to exchange the sensor without having to recalibrate the measuring chain. By means of an amplifier the sensor output signal can be converted, for instance, to a standard signal (0 ... 10 V, 0/4 ... 20 mA), or can be sent directly to a PC through a USB interface. Accurate display and evaluation units complement the range of possible applications.

The sensors, particularly those with small measuring ranges, must be mounted carefully. It is important that the drive and measuring ends are not reversed during assembly. The measuring shaft should always be cleaned prior to assembly, to ensure that no foreign objects are sticking to it. It is recommended that the sensor is electrically connected and that the output signal is observed at the time of assembling. Vibrations originating in the equipment should be kept away from the sensor. The sensor should only be mounted on the coupling after the parts have been accurately aligned. This should be done without backlash or lateral forces.

Technical Data

Order Code	Measuring Range	Dimensions [mm]								Sensitivity [mV/V]	Utility Moment % F.S.	Max. Utility Moment % F.S.	Overload Moment % F.S.	Weight [g]
		A	B	C	D	E	F	G						
8625 - 4005	0 ... ± 0.5 Ncm	37	48	5	4g6	5,5	26	14	0.5	200	300	500	120	
8625 - 4010	0 ... ± 1 Ncm	37	48	5	4g6	5,5	26	14	0.5	200	300	500	120	
8625 - 4020	0 ... ± 2 Ncm	37	48	5	4g6	5,5	26	14	0.5	200	300	500	120	
8625 - 4050	0 ... ± 5 Ncm	48	65	7	6g6	8	32	25	0.5	200	300	500	180	
8625 - 4100	0 ... ± 10 Ncm	48	85	17	8g6	18	32	25	0.5	200	300	500	240	
8625 - 4200	0 ... ± 20 Ncm	48	85	17	8g6	18	32	25	0.8	150	200	300	240	
8625 - 4500	0 ... ± 50 Ncm	48	85	17	8g6	18	32	25	0.8	150	200	300	240	
8625 - 5001	0 ... ± 1 Nm	48	85	17	8g6	18	32	25	0.8	150	200	300	240	
8625 - 5002	0 ... ± 2 Nm	48	85	17	8g6	18	32	25	0.8	150	200	300	240	
8625 - 5005	0 ... ± 5 Nm	48	85	17	8g6	18	32	25	0.8	150	200	300	240	
8625 - 5010	0 ... ± 10 Nm	48	85	17	10h6	18	32	25	0.8	150	200	300	240	
8625 - 5020	0 ... ± 20 Nm	73	111.5	18	18h6	19	51	40	0.8	150	200	300	320	
8625 - 5050	0 ... ± 50 Nm	73	147.5	36	18h6	37	51	40	0.8	150	200	300	410	
8625 - 5100	0 ... ± 100 Nm	73	147.5	36	18h6	37	51	40	0.8	150	200	300	410	
8625 - 5200	0 ... ± 200 Nm	79.5	159.5	38	32h6	40	66	40	0.8	150	200	300	460	
8625 - 5500	0 ... ± 500 Nm	79.5	159.5	38	32h6	40	66	40	0.8	150	200	300	460	
8625 - 6001	0 ... ± 1000 Nm	107	262	58	50h7	66	97	53.5	0.8	150	200	300	1200	
8625 - 6002	0 ... ± 2000 Nm	135	377	110	70h7	126	112	53.5	0.8	150	200	300	2800	
8625 - 6005	0 ... ± 5000 Nm	135	377	110	70h7	126	112	53.5	0.8	150	200	300	2800	

Higher measurement ranges on request.

Electrical values

Bridge resistance (strain gauge full bridge): 1000 Ω
 Power excitation: 2 ... 12 V
 recommended 10 V

Environmental conditions

Operating temperature range: - 15 °C ... + 55 °C
 Nominal temperature of operating range: - 5 °C ... + 45 °C
 Sensitivity of temperature effects:
 at zero: ± 0.01 % F.S./K
 on characteristic: ± 0.003 % Rdg./K

Mechanical values

Non-linearity and hysteresis: ≤ ± 0.1 % F.S.
 Repeatability: ≤ ± 0.02 % F.S.
 Dynamic overload safe: up to 70 % from nominal value
 Twist angle by nominal load: approx. 0.2°
 Material: steel 1.2826 res. 1.2738
 Protection class: acc. EN 60529 IP50

Electrical values

Measurement range ≤ 10 Nm: 7 pins plug connection
 Measurement range ≥ 20 Nm: 6 pins plug connection
 (mating connector included on sensor delivery)

Pins assignment:	6 pole connector	7 pole connector
excitation -	1	1
excitation +	2	2
shield	3 (open)	3 (open)
signal +	4	4
signal GND	5	5
NC	6	7

Order Information

Torque sensor, range ± 100 Nm **Model 8625-5100**

Accessories

- for sensor with 6 pins plug**
- Mating connector, 6 pole **Model 9953**
- Mating connector, 6 pole, 90°- angle **Model 9900-V589**
- Connecting cable, length 3 m, on one end mating connector 9953 **Model 99553-000A-0110030**
- Connecting cable, length 3 m for burster desktop instruments, for model 9235 and model 9310 **Model 99141-553A-0150030**
Model 99209-553A-0110030

Model 8625 measurement ranges up to 0 ... 0.02 Nm

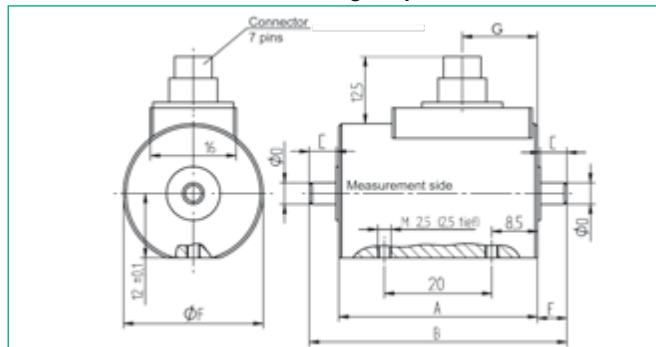

Model 8625 measurement ranges from 0 ... 0.05 Nm

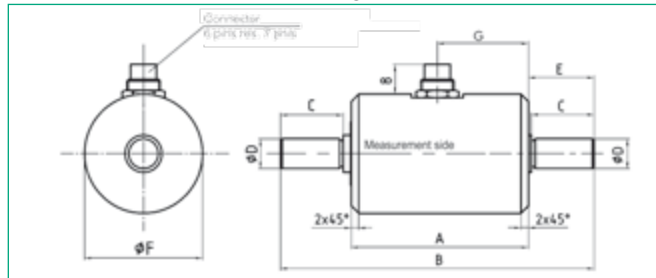

The CAD drawing (3D/2D) for this sensor can be imported online directly into your CAD system.

Download via www.burster.com or directly at www.traceparts.com. For further information about the burster traceparts cooperation refer to data sheet 80-CAD-EN.

Accessories

- for sensor with 7 pins plug**
- Mating connection, 7 pole **Model 9900-V594**
- Mating connection, 7 pole 90°- angle **Model 9900-V596**
- Connection cable, length 3 m, on one end mating connector 9900-V594, other end free **Model 99594-000A-0150030**
- Connecting cable, length 3 m for burster desktop instruments **Model 99141-594A-0150030**
- for model 9235 and model 9310 **Model 99209-594A-0150030**

Manufacturer Calibration Certificate (WKS)

Special calibration for clockwise or/and counter clockwise direction torque, 20 % steps of range up and down.