

# T10FS

## Torque Flange



### Special features

- Nominal (rated) torques: 100 N·m, 200 N·m, 500 N·m, 1 kN·m, 2 kN·m, 3 kN·m, 5 kN·m, 10 kN·m
- Nominal speed from 12,000 rpm to 24,000 rpm
- Low rotor weights
- Small mass moments of inertia
- Small outside diameters
- Non-contacting
- Option: integrated magnetic or optical speed measuring system

### Installation example

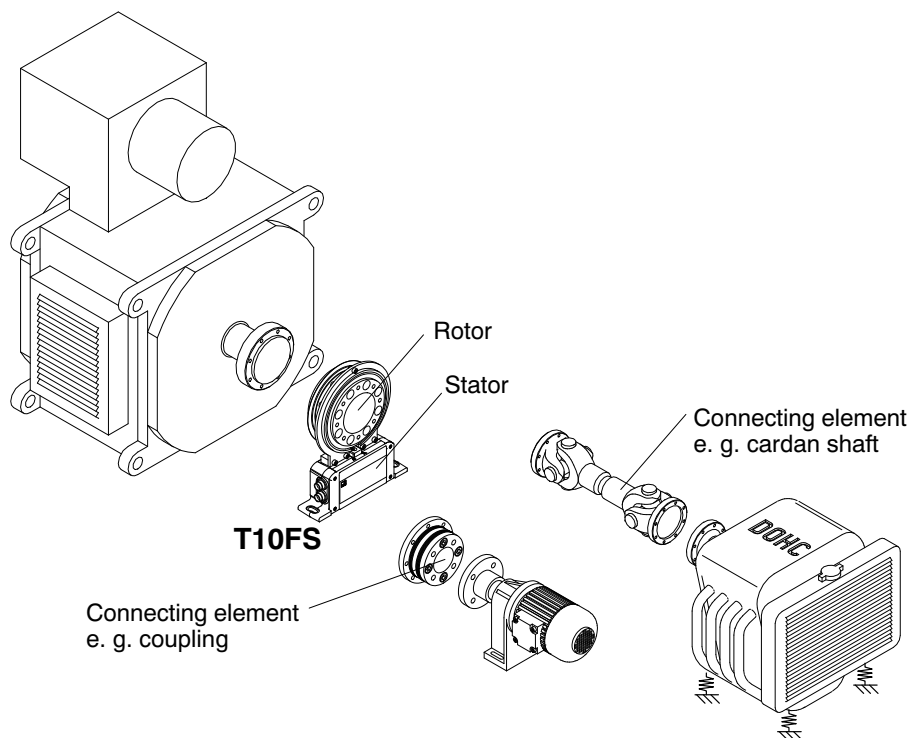

## Specifications

Type	T10FS								
<b>Accuracy class</b>	0.05								
<b>Torque measuring system</b>									
<b>Nominal (rated) torque <math>M_{nom}</math></b> for reference only	N·m	100	200	500	1 k	2 k	3 k	5 k	10 k
	ft·lb	75	150	375	750	1,500	2,250	3,750	7,500
<b>Nominal sensitivity</b> (range between torque = zero and nominal (rated) torque)									
Frequency output	kHz	5							
Voltage output	V	10							
<b>Characteristic tolerance</b> (deviation of the actual output quantity at $M_{nom}$ from the nominal sensitivity)									
Frequency output	%	± 0.1							
Voltage output	%	± 0.2							
<b>Output signal at torque = zero</b>									
Frequency output	kHz	10							
Voltage output	V	0							
<b>Nominal output signal</b>									
Frequency output with positive nominal (rated) torque	kHz	15 (5 V symmetric <sup>1</sup> )/12 V asymmetric <sup>2</sup> )							
Frequency output with negative nominal (rated) torque	kHz	5 (5 V symmetric <sup>1</sup> )/12 V asymmetric <sup>2</sup> )							
Voltage output with positive nominal (rated) torque	V	+10							
Voltage output with negative nominal (rated) torque	V	-10							
<b>Load resistance</b>									
Frequency output	kΩ	≥ 2							
Voltage output	kΩ	≥ 5							
<b>Long-term drift over 48 h</b>									
Voltage output	mV	≤ ± 3							
<b>Measurement frequency range</b>									
Voltage output	Hz	0 ... 1000 (-3 dB)							
<b>Group delay time</b>									
Frequency output	ms	0.15							
Voltage output	ms	0.9							
<b>Residual ripple</b>									
Voltage output	mV	40 (peak-to-peak)							
<b>Temperature influence per 10 K in the nominal temperature range on the output signal, related to the actual value of signal span</b>									
Frequency output	%	< ± 0.05							
Voltage output	%	< ± 0.15							
<b>on the zero signal, related to the nom. sensitivity</b>									
Frequency output	%	< ± 0.05 (< ± 0.03 optional)							
Voltage output	%	< ± 0.15 (< ± 0.13 optional)							
<b>Max. modulation range<sup>3)</sup></b>									
Frequency output	kHz	4...16							
Voltage output	V	-10.5...+10.5 (typ. ± 11)							
<b>Power supply (version KF1)</b>									
Excitation voltage (square wave)	V	54 ± 5% (peak-to-peak)							
Release of calibration signal	V	80 ± 5 %							
Frequency	kHz	approx. 14							
Max. current consumption	A	1 (peak-to-peak)							
<b>Preamplifier excitation voltage</b>	V	0/0/+15							
<b>Preamplifier, max. current consumption</b>	mA	0/0/+25							
<b>Power supply (version SF1/SU2)</b>									
Nominal supply voltage (protective low voltage)	V (DC)	18 ... 30; asymmetric							
Current consumption in measuring mode	A	< 0.9							
Current consumption in start-up mode	A	< 2							
<b>Nominal (rated) power consumption</b>	W	< 12							

<sup>1)</sup> RS 422 complementary signals; factory settings version SF1/SU2

<sup>2)</sup> Factory settings version KF1 (no switching possible)

<sup>3)</sup> Output signal range with a repeatable interrelationship between torque and output signal.

## Specifications (Continued)

Nominal (rated) torque $M_{nom}$ for reference only	N-m	100	200	500	1 k	2 k	3 k	5 k	10 k
	ft-lb	75	150	375	750	1,500	2,250	3,750	7,500
<b>Linearity deviation including hysteresis, related to the nominal sensitivity</b>									
Frequency output	%	< ±0.05 (< ±0.03 optional)							
Voltage output	%	< ±0.07 (< ±0.05 optional)							
<b>Rel. standard deviation of the reproducibility</b> according to DIN 1319, by reference to variation of the output signal									
Frequency output	%	< ±0.03		< ±0.02					
Voltage output	%	< ±0.03							
<b>Calibration signal</b>		approx. 50 % of $M_{nom}$ ; value given to the identification plate							
<b>Tolerance of calibration signal related to <math>M_{nom}</math></b>	%	< ±0.05							
<b>Magnetic speed measuring system</b>									
<b>Speed measuring system</b>		magnetic by MR (Magneto-Resistive)-Sensor and magnetized plastic ring in stainless steel ring. Multiplication by realtime evaluation method.							
<b>Magnetic poles</b>	Number	120	144	180					
<b>Pulse tolerance</b>									
with evaluation factor 1 per pole	degree	< 0.1							
with factory default for evaluation factor	degree	< 0.2 (typ. < 0.1)							
<b>Pulses per revolution</b>									
Possible settings <sup>4)</sup> (evaluation factor per pole)	Number	120 (1); 480 (4); 600 (5); 960 (8); 1200 (10)	144 (1); 576 (4); 720 (5); 1152 (8); 1440 (10)	180 (1); 720 (4); 900 (5); 1440 (8); 1800 (10)					
Factory setting	Number	600 (5)		720 (5) <sup>5)</sup>			720 (4)		
Possible settings with output pulse division <sup>4)</sup>	Number	10 ... 1200		12 ... 1440			15 ... 1800		
<b>Output signal</b>	V	5 <sup>6)</sup> symmetric 2 square wave signals approx. 90° phase shifted							
<b>Max. output frequency</b>	kHz	250							
<b>Minimum speed for sufficient pulse stability</b>	rpm	0							
<b>Group delay time</b>	µs	< 5 (typ. 1.3)							
<b>Hysteresis of reversing the direction of rotation<sup>7)</sup></b> with relative vibrations between rotor and stator									
Torsional rotor vibrations	degree	< approx. 1							
Radial stator vibrations	mm	< approx. 1							
<b>Load resistance</b>	kΩ	≥2 (Maintain termination resistors acc. to RS-422)							
<b>Magnetic load limits</b>	kΩ								
Residual flux density	mT	>100							
Coercive field strength	kA/m	>100							
<b>Permissible magnetic field strength for signal deviations of 0.1 degree per pole</b>	kA/m	<0.1							
<b>Nominal (rated) clearance (sensor-pole ring)</b>	mm	1.0						1.2	
<b>Working distance range</b>	mm	0.3 ... 1.8						0.3 ... 2.2	
<b>Maximum permissible radial displacement between rotor and stator</b>	mm	See working distance range of the magnetic system; can be adjusted by 1.5 mm at the sensor head							

4) When adjusting higher output pulse factors, take into account the maximum permissible output frequency of 250 kHz.

5) Max. permissible rotational speed for speed measurement: 20,500 rpm. At higher rotational speeds, smaller output pulses must be adjusted.

6) RS422 complementary signals

7) Can be switched off

## Specifications (Continued)

Nominal (rated) torque $M_{nom}$ for reference only	N·m	100	200	500	1 k	2 k	3 k	5 k	10 k
	ft·lb	75	150	375	750	1,500	2,250	3,750	7,500
<b>Optical speed measuring system</b>									
<b>Speed measuring system</b>	optical, by means of infrared light and metallic slotted disc								
<b>Mechanical increments</b>	Number	360						720	
<b>Positional tolerance of the increments</b>	mm	± 0.05							
<b>Tolerance of the slot width</b>	mm	± 0.05							
<b>Pulses per rotation (electrically adjustable)</b>	Number	360 <sup>*)</sup> ; 180; 90; 60; 30; 15						720; 360 <sup>*)</sup> ; 180; 90; 60; 30; 15	
<b>Output signal</b>	V	5 <sup>8)</sup> symmetric; 2 square wave signals approx. 90° phase shifted							
<b>Minimum speed for sufficient pulse stability</b>	rpm	2							
<b>Group delay time</b>	µs	< 5 (typ. 2.2)							
<b>Hysteresis of reversing the direction of rotation<sup>9)</sup></b> with relative vibrations between rotor and stator									
Torsional rotor vibrations	degree	< approx. 2							
Radial stator vibrations	mm	< approx. 2							
<b>Load resistance</b>	kΩ	≥ 2 (Maintain termination resistors acc. to RS-422)							
<b>Permitted degree of soiling</b> , in the optical path of the sensor fork (lenses, slotted disc)	%	< 50							
<b>Measuring system: reference pulse</b>									
<b>Measuring system</b>	magnetic by magnetic-field dependent resistor and magnet, synchronized with rising <sup>*)</sup> or falling edge of the optical speed measuring system's 0° output signal								
<b>Output signal</b>	V	5 symmetric							
<b>Pulse width</b>		0.5 degrees with 360 speed pulses/rev. (factory settings)							
<b>Pulses per revolution</b>		1							
<b>Minimum speed for sufficient pulse stability</b>	rpm	2							
<b>Group delay time</b>	µs	< 5 (typ. 2.2)							
<b>Additional phase error with</b>									
< 20 rpm	degree	typ. < 0.1; leading							
> 20 rpm	degree	negligible							
<b>Repeatability with 360 speed pulses/rev.</b>	degree	typ. < ± 0.04 (ideal mounting, non-vibrating operation)							

\*) Factory setting

8) RS 422 complementary signals

9) Can be switched off

## Specifications (Continued)

Nominal (rated) torque $M_{nom}$ for reference only	N-m	100	200	500	1 k	2 k	3 k	5 k	10 k	
	ft-lb	75	150	375	750	1,500	2,250	3,750	7,500	
<b>General data</b>										
<b>EMC</b>										
<b>EME</b> (Emission according to EN61326-1, table 4) RFI field strength	-	Class B								
<b>Immunity from interference</b> (EN61326-1, table A.1)										
Electromagnetic field AM	V/m	10								
Magnetic field	A/m	30								
<b>ESD</b>										
Contact discharge	kV	4								
Air discharge	kV	8								
Burst	kV	1								
Surge	kV	1								
Line-conducted disturbance (AM)	V	3								
<b>Degree of protection according to EN 60 529</b>										
IP 54										
<b>Weight, approx.</b>										
Rotor	kg	1.9	1.9	2.4	2.4	4.9	4.9	8.3	14.6	
Stator	kg	1.2	1.2	1.2	1.2	1.3	1.3	1.3	1.3	
<b>Reference temperature</b>										
°C [°F] +23 [73.4]										
<b>Nominal temperature range</b>										
°C [°F] +10...+60 [+50...+140]										
<b>Service temperature range</b>										
°C [°F] -10...+60 [+14...+140]										
<b>Storage temperature range</b>										
°C [°F] -20...+70 [-4...+158]										
<b>Impact resistance, test severity level to IEC 68; part 2-27; IEC 68-2-27-1987</b>										
Number of impacts	n	1000								
Duration	ms	3								
Acceleration (half-sine)	m/s <sup>2</sup>	650								
<b>Vibration resistance, test severity level to IEC 68, part 2-6; IEC 68-2-6-1982</b>										
Frequency range	Hz	5...65								
Duration	h	1.5								
Acceleration (amplitude)	m/s <sup>2</sup>	50								
<b>Nominal speed</b>										
rpm 15,000 12,000 10,000 8,000										
<b>Nominal speed optional</b>										
rpm 24,000 22,000 18,000 14,000 12,000										
<b>Load limits <sup>10)</sup></b>										
<b>Limit torque, related to <math>M_{nom}</math></b>	%	400	200				160			
<b>Breaking torque, related to <math>M_{nom}</math></b>	%	> 800	> 400				> 320			
<b>Axial limit force</b>	kN	5	10	16	19	39	42	80	120	
<b>Lateral limit force</b>	kN	1	2	4	5	9	10	12	18	
<b>Bending limit moment</b>	N·m	50	100	200	220	560	600	800	1,200	
<b>Oscillation bandwidth according to DIN 50100 (peak-to-peak)<sup>*)</sup></b>										
N-m 400 400 1000 2,000 4,000 4,800 8,000 16,000										

\*) With T10FS/200 N·m to 10 k N·m, the nominal (rated) torque must not be exceeded. With T10FS/100 N·m, the nominal (rated) torque may be exceeded by 100 %.

<sup>10)</sup> Each type of irregular stress can only be permitted with its given static load limit (bending moment, lateral or axial load, exceeding the nominal (rated) torque) if none of the others can occur. Otherwise the limit values must be reduced. If for instance 30 % of the bending limit moment and also 30 % of the lateral limit force are present, only 40 % of the axial limit force are permitted, provided that the nominal (rated) torque is not exceeded. With the permitted bending moments, axial, and lateral limit forces, measuring errors of about 0.3 % of the nominal (rated) torque can occur.

## Specifications (Continued)

Nominal (rated) torque $M_{nom}$ for reference only	N-m	100	200	500	1 k	2 k	3 k	5 k	10 k
	ft-lb	75	150	375	750	1,500	2,250	3,750	7,500
<b>Mechanical values</b>									
<b>Torsional stiffness <math>c_T</math></b>	kN-m/ rad	270	270	540	900	2,300	2,600	4,600	7,900
<b>Torsion angle at <math>M_{nom}</math></b>	degree	0.022	0.043	0.055	0.066	0.049	0.066	0.06	0.07
<b>Axial stiffness <math>c_a</math></b>	kN/mm	800	800	740	760	950	1,000	950	1,600
<b>Radial stiffness <math>c_r</math></b>	kN/mm	290	290	550	810	1,300	1,500	1,650	2,450
<b>Stiffness with bending moment about a radial axis <math>c_b</math></b>	kN-m/ degree	7	7	11.5	12	21.7	22.4	43	74
<b>Maximum excursion at axial limit force</b>	mm	< 0.02		< 0.03		< 0.05		< 0.1	
<b>Additional max. concentricity error at lateral limit force</b>	mm	< 0.02							
<b>Additional plane-parallel deviation at bending limit moment</b>	mm	< 0.03		< 0.05		< 0.07		< 0.07	
<b>Balance quality-level to DIN ISO 1940</b>		G 2.5							
<b>Max. limits for relative shaft vibration (peak-to-peak)<sup>11)</sup></b> Undulations within the range of the connecting flanges per ISO 7919-3									
Normalmode (continuous operation)	μm	$s_{(p-p)} = \frac{9000}{\sqrt{n}}$							
Start-Stop mode/resonance ranges (temporary)	μm	$s_{(p-p)} = \frac{13200}{\sqrt{n}}$ (n in rpm)							
<b>Mass moment of inertia of the rotor</b>									
$I_V$ (about axis of rotation)	kg·m <sup>2</sup>	0.0026	0.0059	0.0192	0.0370	0.0970			
$I_V$ with optical speed measuring system	kg·m <sup>2</sup>	0.0027	0.0062	0.0196	0.0380	0.0995			
$I_V$ with magnetic speed measuring system	kg·m <sup>2</sup>	0.0029	0.0065	0.0203	0.0201	0.0390	0.1		
<b>Proportionate mass moment of inertia of the rotor</b>									
without speed measuring system	%	57	56	54	53				
with optical speed measuring system	%	55	54	53	52				
with magnetic speed measuring system	%	51							
<b>Max. permissible static eccentricity of the rotor (radially)</b>									
without speed measuring system	mm	± 2							
with optical speed measuring system (with or without reference impulse)	mm	± 1							
with magnetic speed measuring system	mm	± 0.7							
<b>Permissible axial displacement between rotor and stator</b>									
without speed measuring system	mm	± 3							
with optical speed measuring system (with or without reference impulse)	mm	± 2							
with magnetic speed measuring system	mm	± 1.5							

<sup>11)</sup> The effects of radial deviation, eccentricity, defect of form, notches, marks, local residual magnetism, structural inhomogeneity or material anomalies on vibration measurements need to be taken into account and distinguished from the actual undulation.

**Dimensions Rotor (in mm; 1 mm=0.03937 inches)**

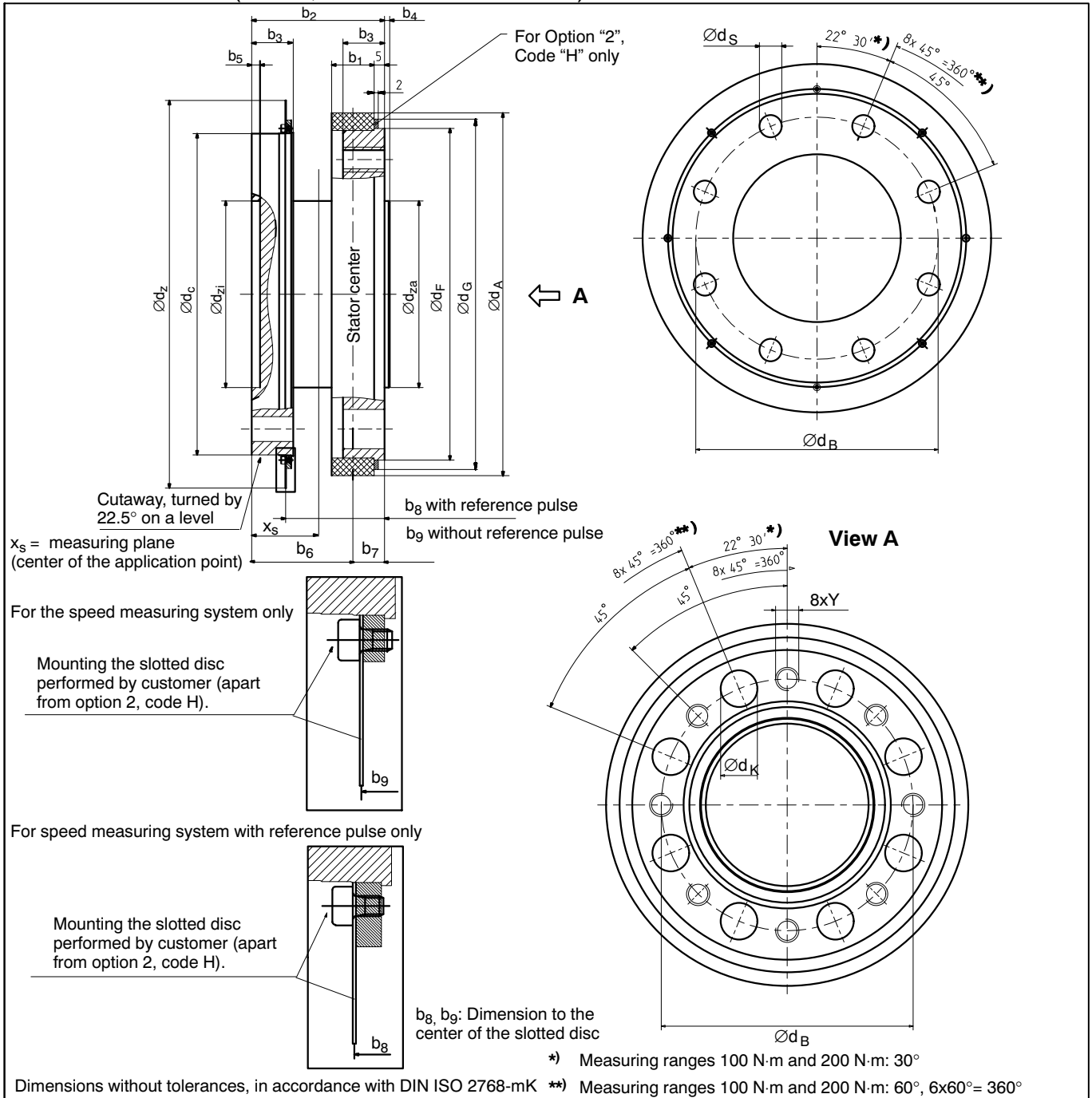

Measuring range	Dimensions in mm										
	b <sub>1</sub>	b <sub>2</sub>	b <sub>3</sub>	b <sub>4+0.4</sub>	b <sub>5</sub>	b <sub>6</sub>	b <sub>7</sub>	b <sub>8</sub>	b <sub>9</sub>	x <sub>S</sub>	Y
100 N·m / 200 N·m	17.5	60	18	2	4	46.3	13.7	47.2	47.2	30	M8
500 N·m / 1 kN·m	17.5	60	18	2	4	46.3	13.7	45.5	45	30	M10
2 kN·m / 3 kN·m	20.5	64	20	2.5	4	48.8	15.2	47.5	47	32	M12
5 kN·m	22.5	84	26	2.8	3	67.8	16.2	62.7	62.7	42	M14
10 kN·m	28.5	92	30	3.5	4	72.8	19.2	66.7	66.7	46	M16

Measuring range	Dimensions in mm									
	Ød <sub>A</sub>	Ød <sub>B</sub>	Ød <sub>C</sub>	Ød <sub>F</sub>	Ød <sub>G</sub>	Ød <sub>k</sub>	Ød <sub>S</sub> <sup>C12</sup>	Ød <sub>Z</sub>	Ød <sub>Za</sub> <sup>g5</sup>	Ød <sub>Zi</sub> <sup>H6</sup>
100 N·m / 200 N·m	119	84	99	101	110	14	8.2	131	57	57
500 N·m / 1 kN·m	139	101.5	120	124	133	17	10	151	75	75
2 kN·m / 3 kN·m	175	130	155	160	169	19	12	187	90	90
5 kN·m	209	155.5	180	188	-	22	14.2	221	110	110
10 kN·m	256	196	222	230	-	26	17	269	140	140

**Dimensions rotor with magnetic speed measuring system (in mm 0.03937 inches)**

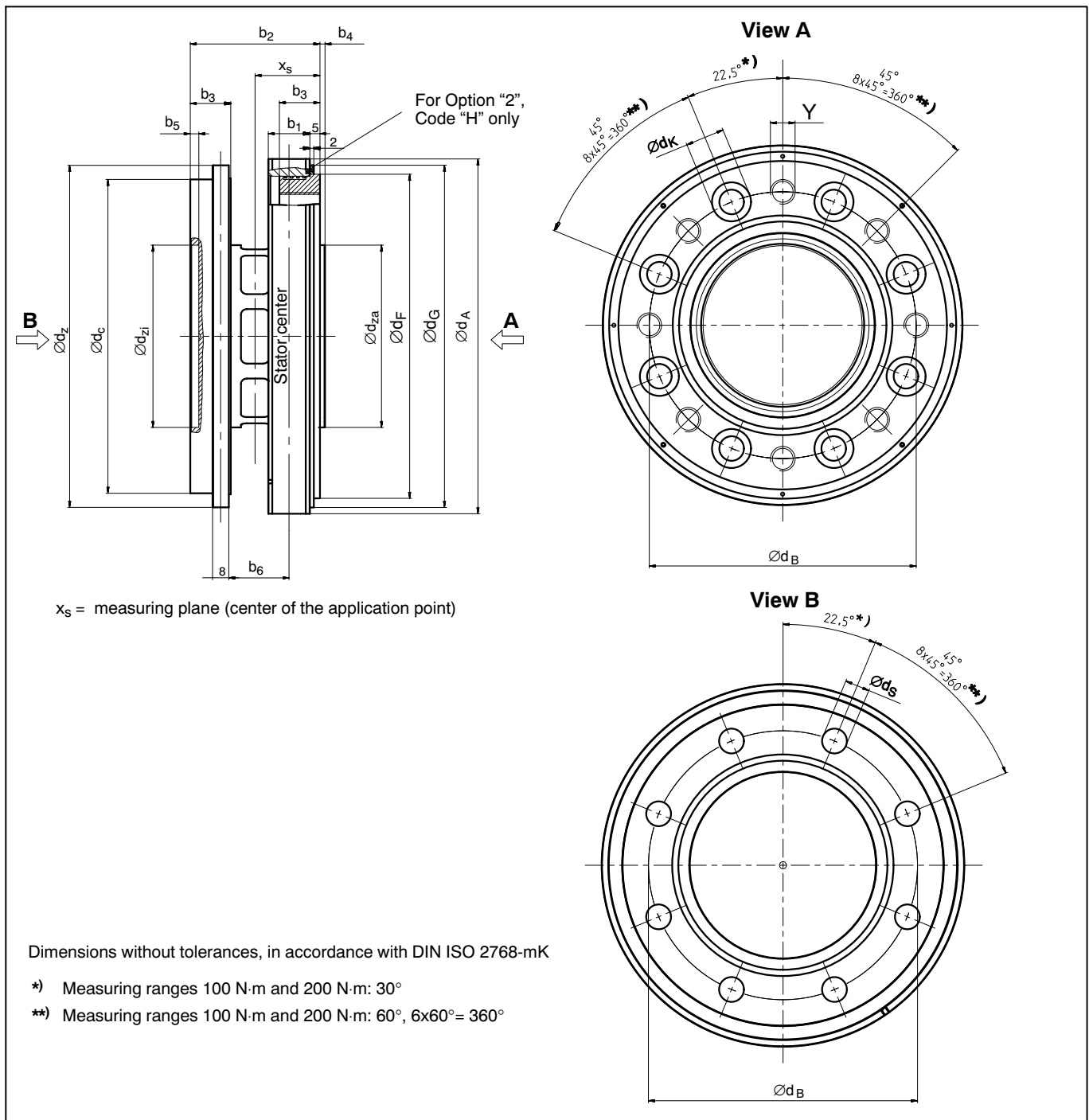

Measuring range	Dimensions in mm																	
	Ød <sub>A</sub>	Ød <sub>B</sub>	Ød <sub>C</sub>	Ød <sub>F</sub>	Ød <sub>G</sub>	Ød <sub>K</sub>	Ød <sub>S</sub> <sup>C12</sup>	Ød <sub>Z</sub>	Ød <sub>za g5</sub>	Ød <sub>zi</sub> <sup>H6</sup>	b <sub>1</sub>	b <sub>2</sub>	b <sub>3</sub>	b <sub>4+0.4</sub>	b <sub>5</sub>	b <sub>6</sub>	x <sub>S</sub>	Y
100 N·m / 200 N·m	119	84	99	101	110	14	8.2	112.9	57	57	17.5	60	18	2	4	31	30	6xM8
500 N·m / 1 kN·m	139	101.5	120	124	133	17	10	132.9	75	75	17.5	60	18	2	4	29	30	8xM10
2 kN·m / 3 kN·m	175	130	155	160	169	19	12	168.9	90	90	20.5	64	20	2.5	4	30	32	8xM12
5 kN·m	209	155.5	180	188	-	22	14.2	192.5	110	110	22.5	84	26	2.8	3	44	42	8xM14
10 kN·m	256	196	222	230	-	26	17	239.7	140	140	28.5	92	30	3.5	4	45	46	8xM16



# Dimensions Stator (in mm; 1 mm=0.03937 inches)

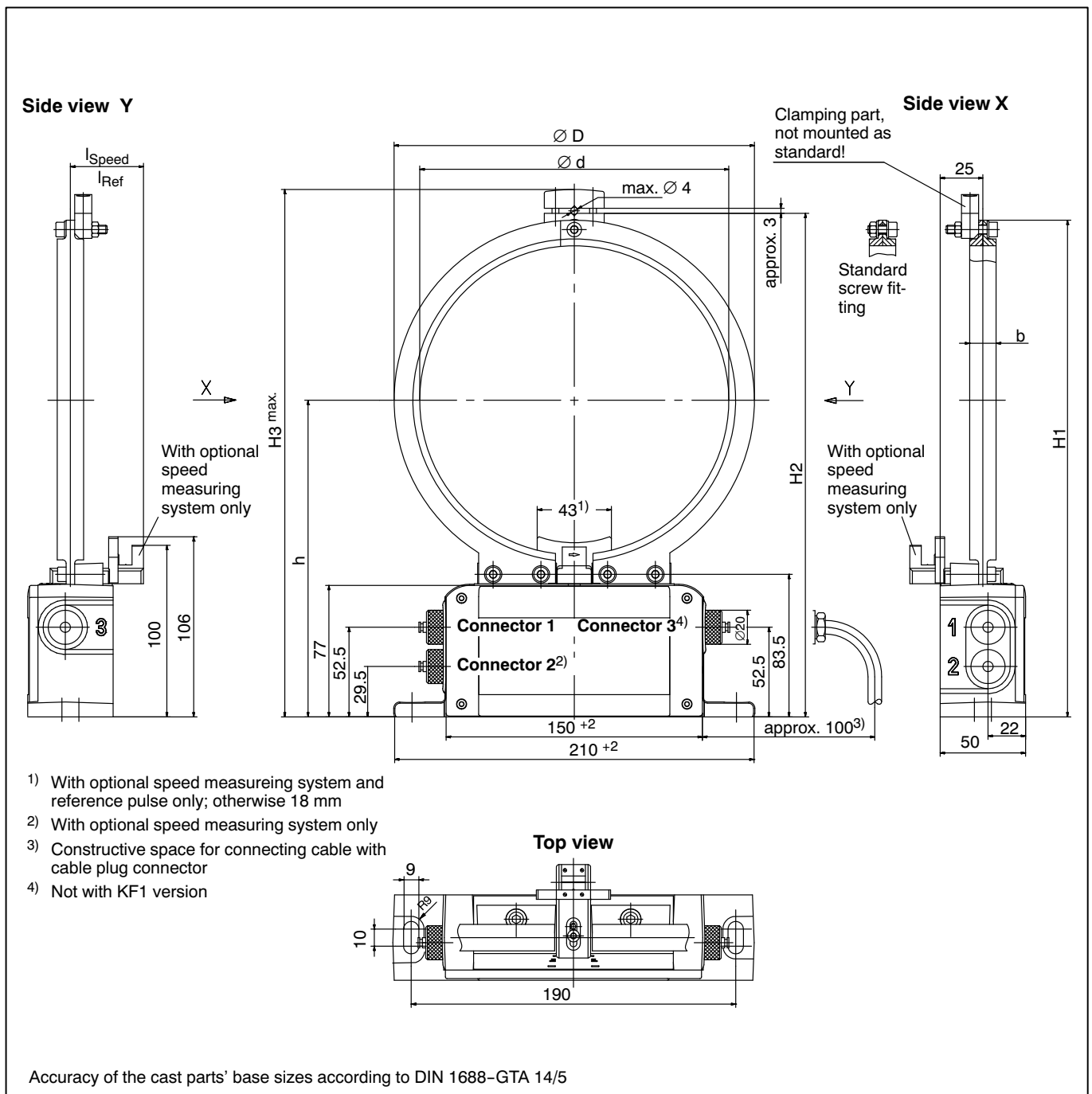

Measuring range	Dimension in mm								
	b	Ød	ØD	H1	H2	H3	h	l <sub>Speed</sub>	l <sub>Ref</sub>
100 N·m 200 N·m	17.5	125	155	235	239	253	157.5	42.5	42.5
500 N·m 1 kN·m	17.5	145	175	255	259	273	167.5	42	42.5
2 kN·m 3 kN·m	20.5	181	211	291	295	309	185.5	42.5	43
5 kN·m	22.5	215	245	324	329	343	202.5	57	57
10 kN·m	28.5	263	293	373	377	391	226.5	58	58

# Dimensions of stator with magnetic speed measurement (in mm 0.03937 inches)

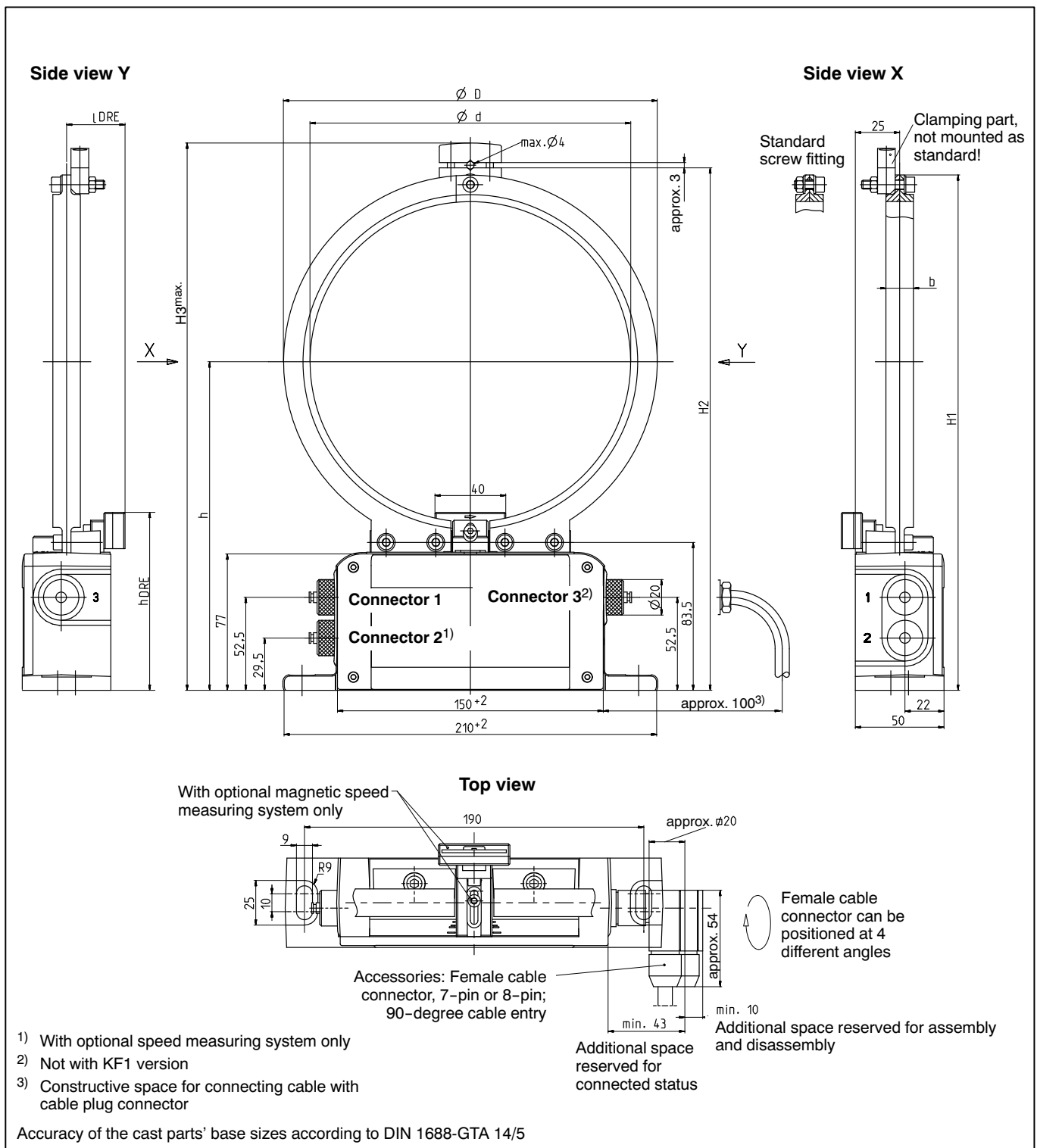

Measuring range	Dimensions in mm								
	b	∅d	∅D	H1	H2	H3	h	l <sub>DRE</sub>	h <sub>DRE</sub> *
100 N·m 200 N·m	17.5	125	155	235	239	253	157.5	38	100
500 N·m 1 kN·m	17.5	145	175	255	259	273	167.5	36	100
2 kN·m 3 kN·m	20.5	181	211	291	295	309	185.5	37	100
5 kN·m	22.5	215	245	325	329	343	202.5	51	105.5
10 kN·m	28.5	263	293	373	377	391	226.5	52	105.5

\*) Can be adjusted by 1.5 mm at sensor head.

## T10FS versions

T10FS version <sup>*)</sup>		KF1	SF1	SU2
Measured quantity				
Torque		■	■	■
Speed magnetic or optical (Option)			■	■
Speed and reference pulse (Option)			■	■
Power supply				
Excitation voltage 54 V <sub>pp</sub> /14 kHz, square wave		■		
Supply voltage 18 V...30 V DC			■	■
Output signal				
10 kHz ± 5 kHz		■	■	■
± 10 V				■
Connecting cable	Torque	V1, V2, V3, V4	V5, V6	V5, V6
	Speed		W1, W2	W1, W2
	Speed and reference pulse		W5, W6	W5, W6

<sup>\*)</sup> Description of versions, see last page.

## Screw fitting of the rotor

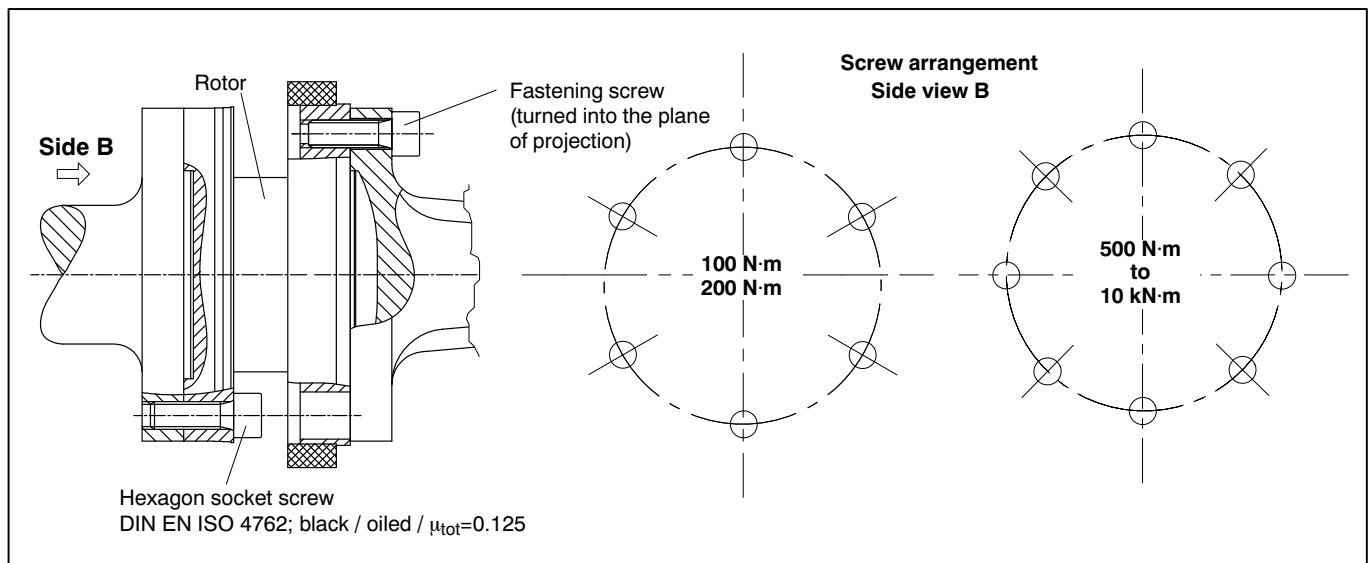

Nominal (rated) torque (N·m)	Fastening screws	Fastening screws class	Prescribed fastening torque (N·m)
100	M8	10.9	34
200			
500	M10	10.9	67
1 k			
2 k	M12	12.9	115
3 k			
5 k	M14	12.9	220
10 k	M16	12.9	340

**Dimensions** (in mm; 1mm=0.03937 inches)

Measuring range	Dimension "m" (mm)	Area free of metal parts (mm)	
		a	x
		100 N·m 200 N·m	20
500 N·m 1 kN·m	28.5		
2 kN·m 3 kN·m	28.5		
5 kN·m	31.5		
10 kN·m	34.5		

It is essential to maintain the specified mounting dimensions to ensure proper functioning.

**Flatness and concentricity tolerances**

circular run-out-axial AB

circular run-out-radial AB

**Internal centering**

Hardness 46 ... 54 HRC

Surface quality of in-plane and concentric surfaces (A, B and AB)  $\sqrt{0.8}$

Measuring range	Circular run-out-axial tolerance (mm)	Circular run-out-radial tolerance (mm)
100 N·m	0.01	0.01
200 N·m	0.01	0.01
500 N·m	0.01	0.01
1 kN·m	0.01	0.01
2 kN·m	0.02	0.02
3 kN·m	0.02	0.02
5 kN·m	0.02	0.02
10 kN·m	0.02	0.02

## Ordering number

Code	Option 1: Measuring range
100Q	100 N·m
200Q	200 N·m
500Q	500 N·m
001R	1 kN·m
002R	2 kN·m
003R	3 kN·m
005R	5 kN·m
010R	10 kN·m

Code	Option 2: Nominal speed
L	Normal speed depending on meas. range 8,000 rpm to 15,000 rpm
H	Normal speed depending on meas. range 12,000 rpm to 24,000 rpm

Code	Option 3: Electrical configuration
KF1	Output signal 10 kHz $\pm$ 5 kHz, Supply voltage 14 kHz / 54 V; square wave
SF1	Output signal 10 kHz $\pm$ 5 kHz, Supply voltage 18...30 V DC
SU2	Output signal 10 kHz $\pm$ 5 kHz and $\pm$ 10 V, Supply voltage 18...30 V DC

Code	Option 4: Accuracy
S	Standard
G	Increased accuracy <sup>1)</sup> Lin. $< \pm 0.03\%$ and $TK_0 < \pm 0.03\%$

Code	Option 5: Speed measuring system <sup>2)</sup>
0	Without speed measuring system
1	With optical speed measuring system, 360 pulses/revolution
A	With optical speed measuring system, 360 pulses/revolution and reference pulse
M	With magnetic speed measuring system, 600/720 pulses/revolution

Code	Option 6: Connection cable
V0	Without connecting cable
V1	Torque connecting cable for KF1, 423-free ends, 6 m
V2 <sup>3)</sup>	Torque connecting cable for KF1, 423-free ends, max. 80 m
V3	Torque connecting cable for KF1, 423-MS3106PEMV, 6 m
V4 <sup>3)</sup>	Torque connecting cable for KF1, 423-MS3106PEMV, max. 80 m
V5	Torque connecting cable for SF1/SU2, 423-D-Sub 15P, 6 m
V6 <sup>3)</sup>	Torque connecting cable for SF1/SU2, 423-D-Sub 15P, max. 50 m
W1	One torque and speed cable each, 423-D-Sub 15P, 6 m
W2 <sup>3)</sup>	One torque and speed cable each, 423-D-Sub 15P, max. 50 m
W5	One cable for torque and speed each with reference pulse, 423-free ends, 6 m
W6 <sup>3)</sup>	One cable for torque and speed each with reference pulse, 423-free ends, max. 50 m

Code	Option 7: Accessories
N	Without accessories

- 1) With voltage output: Lin.  $< \pm 0.05\%$  ;  $TK_0 < \pm 0.13\%$   
 2) Only option 3, Code SF1, SU2

Order no.:

K-T10FS - [ ] [ ] [ ] [ ] - [ ] - [ ] [ ] [ ] [ ] - [ ] - [ ] [ ] [ ] [ ] - [ ] [ ] [ ] [ ] m<sup>\*)</sup>

Ordering example:

K-T10FS - [5][0][0][Q] - [H] - [S][F][1] - [S] - [0] - [V][5] - [N] [ ] [ ] [ ] [ ] m<sup>\*)</sup>

\*) With V2, V4, V6, W2 and W6 selected, please specify desired cable length.

### Accessories, to be ordered separately:

423G-7S cable socket, 7-pole, straight cable entry, for torque output (connector 1, 3),  
order no. 3-3101.0247

423W-7S cable socket, 7-pole, 90° cable entry, for torque output (connector 1, 3),  
order no. 3-3312.0281

423G-8S cable socket, 8-pole, straight cable entry, for speed output (connector 2), order no. 3-3312.0120

423W-8S cable socket, 8-pole, 90° cable entry, for speed output (connector 2), order no. 3-3312.0282

Raw cable Kab8/00-2/2/2, order no. 4-3301.0071





Modifications reserved.  
All details describe our products in general form only. They  
are not to be understood as express warranty and do not  
constitute any liability whatsoever.

B0780-11.0 en

**Hottinger Baldwin Messtechnik GmbH**

Im Tiefen See 45, D-64293 Darmstadt, Germany  
Tel.: +49 6151 8030; Fax: +49 6151 803 9100  
E-mail: [support@hbm.com](mailto:support@hbm.com) [www.hbm.com](http://www.hbm.com)



measurement with confidence