

Thunder Scientific Corporation



Humidity Generation,
Calibration and Measurement



Model 1200

***Mini "Two-Pressure"
Humidity Generator***

Model 1200

Mini “Two-Pressure” Humidity Generator

FEATURES

- Accuracy $\pm 0.5\%$ RH
- Traceable to NIST
- Based on NIST Proven Two-Pressure Principle
- Generate: RH, DP, FP, PPM, Multipoint Profiles
- Computerized Internal Transducer Calibration
- Computes System Uncertainties in Real Time
- Automatically Applies Enhancement Factors
- No Refrigerants - Thermoelectric Cooling/Heating
- Only 4 square feet of floor space (20" x 30")
- Touch-screen control
- USB and Ethernet Interface



DESCRIPTION

The Model 1200 Mini Humidity Generator produces accurate humidity values using the fundamental, NIST proven, “two-pressure” principle. The 1200 will automatically supply relative humidity, dew point, frost point, and other calculated values for instrument calibration and evaluation as well as precision environmental testing. This system automatically generates multipoint profiles as well as manually entered humidity levels, while continuously storing and printing system data.

Virtually all functions of the 1200 humidity generator are computer controlled. All desired humidities, temperatures, and time intervals may be programmed. Visual indications of system status are displayed in real time on the computer screen. The automated features of the 1200 allow the generation of known humidity levels completely unattended. This frees the operating technician from the task of monitoring and adjusting.

PRINCIPLE OF OPERATION

The “two-pressure” humidity generation process involves saturating air or nitrogen with water vapor at a known temperature and pressure. The saturated high-pressure air flows from the saturator, through a pressure reducing valve, where the air is isothermally reduced to test pressure at test temperature.

Humidity generation by the 1200 does not depend upon measuring the amount of water vapor in the air, but rather is dependent on the measurements of temperature and pressure alone. System precision is determined by temperature and pressure measurement accuracy, and on the constancy of the measurements throughout. When setpoint equilibration has been reached the indications of saturation temperature, saturation pressure, test temperature, and test pressure, are used in the determination of all hygrometric parameters.

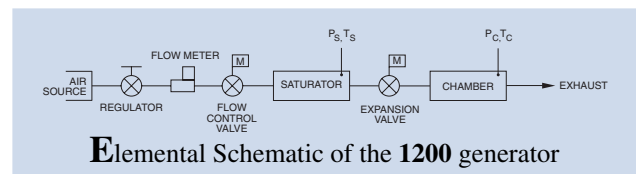

COMPUTER / CONTROL SYSTEM

The Computer/Control System performs all control functions required for humidity generation, as well as displaying, printing, and storing system parameters in real time. The computer/controller is made up of several main components, each with individual yet cooperative functions. The Computer/Control System utilizes a Windows based computer system that is used to read transducers and temperature sensors; supply digital outputs for control of temperatures, pressures, and mass flow; and control relay outputs for control of system power, heaters, heat pump and circulation pump.

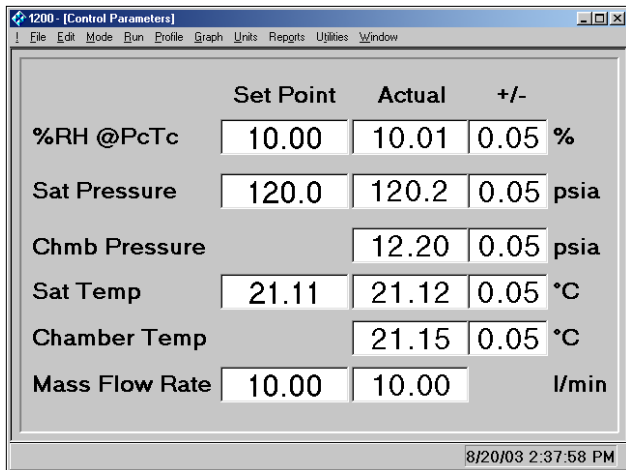

Embedded 1200 ControlLog™ run screen.

Temperature Control: Ultra stable temperatures are attained through solid-state thermoelectric cooling and heating of a circulating fluid that jackets the test chamber and associated humidity generation components. Chamber and saturation temperatures are governed by this medium which is computer controlled at any value between 10 °C and 60 °C using PID (proportional-integral-derivative) algorithms.

Pressure And Flow Control: Pressure control and mass flow control are accomplished through computer actuation of electromechanical valve assemblies. Saturation pressure and mass flow are measured continuously and controlled using PID algorithms similar to those employed in temperature control.

Calibration: Proper calibration of the temperature sensors and pressure transducer ultimately determines the accuracy of the generator. The system employs an integral programmatic calibration scheme allowing the sensors and transducers to be calibrated while they are electrically connected to the humidity generator. Coefficients for each transducer are calculated by the computer and stored to memory.

TEST CHAMBER

The test chamber accommodates various solid-state sensors, data loggers, chilled mirror hygrometers, and material samples for environmental testing. The 1200 humidity generating system incorporates a 300 series stainless steel fluid jacketed test chamber, with internal dimensions of 6" x 6" x 6" (152 mm x 152 mm x 152 mm). Access is available through a 1.625" (41.3 mm) diameter port on the right side for probes, cables, sample tubes, etc.

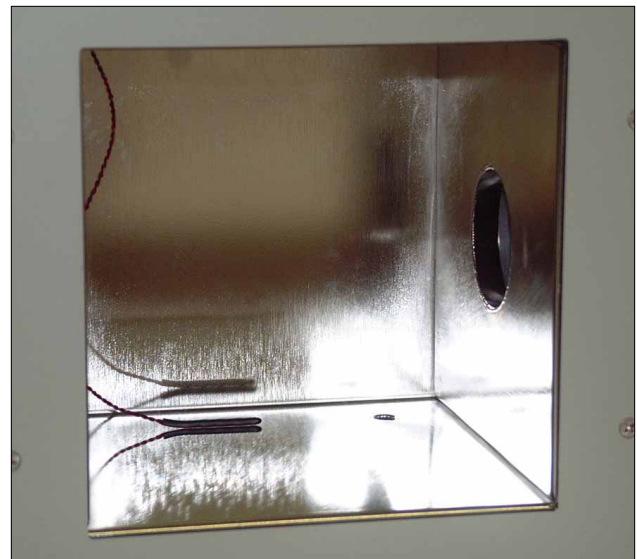

APPLICATIONS FOR USE

Virtually any humidity and temperature may be generated within the operational limits of the generator. The output or recording of the device under test may then be compared with the generator's data for analysis.

Chilled Mirror Hygrometers: Install the actual chilled mirror head into the chamber or insert a sample tube through the test port and draw a sample through the chilled mirror head and you can: verify mirror temperature measurement accuracy (calibration) when the hygrometer is in thermal equilibrium with its environment; perform operational checks of the heat-pump and optical components before and after mirror cleaning and balancing; determine whether the hygrometer is controlling the mirror deposit in the liquid phase or ice phase when operating at dew and frost points below 0 °C; determine if the hygrometer is correctly calculating other humidity parameters; determine the hygrometer's repeatability, stability, and drift characteristics.

Humidity Sensors and Data Loggers: Insert your humidity probes through the chamber access port or install the data logger into the chamber and you can: determine humidity calibration accuracy and/or characterize humidity sensitivity by subjecting the humidity sensor to a variety of humidity levels; perform operational checks such as the sensing systems capability to correctly calculate and display other humidity parameters; determine the repeatability, stability, hysteresis, and drift characteristics of various humidity sensing systems.

Environmental Testing: The 1200 can serve as a test bed for evaluation and R&D of humidity sensors, humidity sensing systems, and humidity sensitive products, e.g., polymers, composites, film, magnetic medium, pharmaceuticals, soil hydrology, consumables, electronics, optics, etc.

Model 1200

Mini "Two-Pressure" Humidity Generator

SPECIFICATIONS

Relative Humidity Range:	10 to 95%
Relative Humidity Resolution:	0.05%
Relative Humidity Accuracy @ PcTc:	±0.5%
Frost Point Temperature Range:	-18 to 0 °C
Dew Point Temperature Range:	-20 to 50 °C
Chamber Temperature Range:	10 to 60 °C
Chamber Temperature Measurement Resolution:	0.02 °C
Chamber Temperature Control Stability:	±0.04 °C
Chamber Temperature Uniformity:	0.1 °C
Chamber Temperature Measurement Accuracy:	±0.05 °C
Chamber Temperature Cooling Rate:	4 Minutes Per °C Average
Chamber Temperature Heating Rate:	2 Minutes Per °C Average
Saturation Pressure Range:	15 to 150 psiA
Saturation Pressure Accuracy:	±0.05 psiA
Saturation Pressure Resolution:	0.02 psiA
Test Chamber Pressure Range:	Ambient
Test Chamber Pressure Resolution:	0.02 psiA
Test Chamber Pressure Accuracy:	±0.05 psiA
Gas Type:	Air or Nitrogen
Gas Pressure Rating (MAWP):	175 psiG
Gas Flow Rate Range:	1 to 10 L/m
Gas Flow Rate Resolution:	0.01 L/m
Gas Flow Rate Accuracy:	±1 L/m
Test Chamber Dimensions:	6" x 6" x 6" (152 mm x 152 mm x 152 mm)
Access Port:	1.625" (41.3 mm) located on right side
Physical Dimensions:	24.10 W" x 14.11 D" x 11.78 H" (61 cm x 35.8 cm x 29.9 cm)
Dry Weight (Generator Only):	56 lbs. (25.40 Kg)
Wet Weight (Generator Only):	65 lbs. (29.48 Kg)

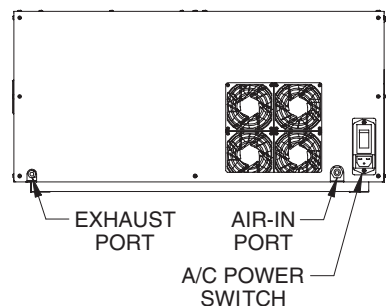
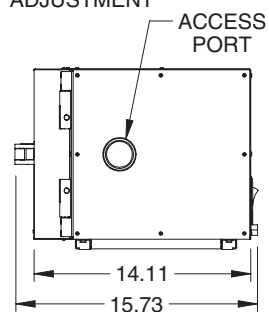
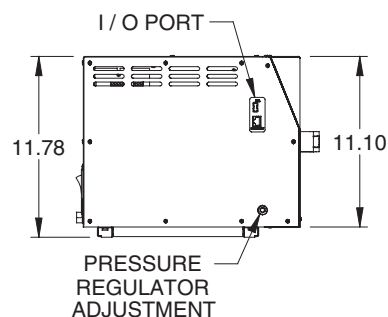
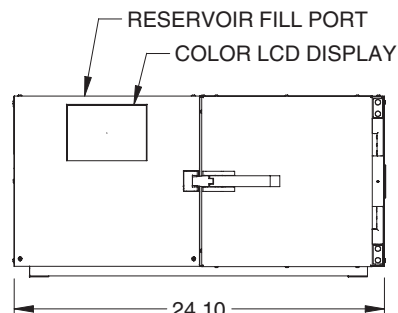

UTILITIES

Electrical Power:	100/240 V, ~ 6 A, 50/60 Hz
Gas Supply:	155-175 psiG @ 0.5 scfm

ENVIRONMENTAL

Operating Temperature:	15 to 30 °C
Storage Temperature:	0 to 50 °C
Humidity:	5 to 95% Non-condensing

For More Information or to Place an Order Contact:

Thunder Scientific

623 Wyoming S.E. • Albuquerque, New Mexico 87123-3198
Ordering: 800.872.7728 • Tel: 505.265.8701 • FAX: 505.266.6203

www.thunderscientific.com